

5 Specifications

5.1 Specification CZ furler

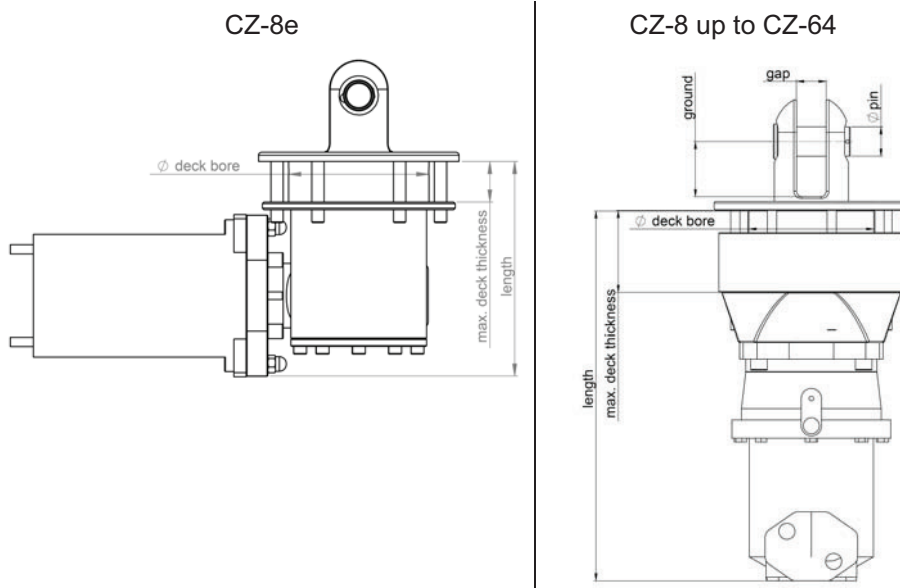

| | CZ-8e | CZ-8 | CZ-16 | CZ-20 | CZ-32 | CZ-64 |
|---------------------------------|-----------|------------|--------------|-------------|-------------|-------------|
| SWL [kg] | 8000 | 8000 | 16000 | 20000 | 32000 | 64000 |
| motor [-] | 800W, 24V | OMR 50/315 | OMT160 FH/FL | OMT400FL/FH | OMT400FL/FH | OMT400FL/FH |
| weight [kg] | 10,2 | 12,2 | 40,66 | 50,76 | 53,51 | 68,33 |
| max. furling moment [Nm] | 50 | 100/560 | 450 | 1100 | 1100 | 1100 |
| at pmax [bar] | - | 140/135 | 200 | 180 | 180 | 180 |
| at I [A] | 50 | - | - | - | - | - |
| furling speed [rpm] | 100 | 100 | 100 | 100 | 100 | 100 |
| at oil flow [l/min] | - | 5/35 | 20 | 40 | 40 | 40 |
| max. rated Voltage [V] | 24 | - | - | - | - | - |
| max. static braking moment [Nm] | - | - | 1200 | 1200 | 1200 | 1200 |
| Pin [mm] | 20 | 20 | 28 | 32 | 38 | 45 |
| Gap [mm] | 19 | 19 | 28 | 32 | 38 | 45 |
| Ground [mm] | 36 | 36 | 53 | 60 | 68 | 60 |
| Length [mm] | 120 | 229 | 355 | 402 | 416 | 434 |
| max. deck thickness [mm] | 26 | 62 | 87,5 | 89 | 97 | 115 |
| req. deck bore [mm] | 91 | 81 | 113 | 135 | 150 | 175 |